



2D Choke Ring Antenna HX-CG7601A

REVOLUTIONARY GNSS ANTENNA
WITH STRONG MULTIPATH
SUPPRESSION



HIGH PHASE CENTER STABILITY

The unique 2D choke ring design of HX-CG7601A ensures an excellent multipath reduction performance across multiple GNSS frequency bands of GPS, BeiDou, GLONASS, GALILEO, QZSS, and SBAS. And the antenna features the Harxon patented multi-point feeding technology to achieve greater phase center stability and hence effectively improve measurement accuracy. It is ideal for applications of CORS stations, bridge and building deformation monitoring or geological monitoring due to its sub-millimeter phase center stability.

TRACKING IN CHALLENGING ENVIRONMENTS

The strong ability to receive low elevation signals with high gain and wide beam width makes HX-CG7601A an excellent choice for tracking visible satellites and provide stable and precision GNSS data under complex environments, such as obstructed environment of tree lines or construction.

STRONG ANTI-INTERFERENCE PERFORMANCE

The antenna LNA features an excellent out-of-band rejection performance, which can suppress the EMI, providing the stability and reliability of GNSS signals. Also it effectively avoids disconnection dangerous when receivers are being interfered by wireless communication systems, for example power grid, communication base station or radio modem applications.

MORE RUGGEDIZED FOR LONG LASTING DURABILITY

The HX-CG7601A cover is made of Glass Fiber Reinforced Polymer(GFRP) material and is structurally strong and reliable. The enclosure of this newly designed choke ring antenna employs multiple protections design to be comfort to IP67 standard, which withstands exposure against dust, rain, splash or sunlight. This reliable and ruggedized design ensures long-term proper operation of the choke ring antenna even under harsh environments as high low temperature, high humidity and salt fog.

KEY FEATURES

- Support GPS, Glonass, Galileo, Beidou, QZSS, and SBAS signal reception
- Stable phase center guarantees the accuracy of positioning within sub-millimeter level
- Strong anti-interference ability to endure the challenging operating environments
- IP67 reliable and ruggedized cover protection





PERFORMANCE

Signal Received

GPS	L1/L2
GLONASS	L1/L2/L3
GALILEO	E1
BDS	B1/B2/B3
QZSS	L1/L2
SBAS	L1

Nominal Impedance 50Ω

Polarization RHCP

Axial Ratio ≤2dB

Gain at Zenith (90°)

1200-1278MHz	6dBi(maximum)
1559-1615MHz	6dBi(maximum)

LNA Gain 50dB(typical)

Noise Figure ≤2dB

Output/Input VSWR ≤2.0

Operation Voltage +3.3VDC to +12VDC

Operation Current 60mA(maximum)

Group Delay Ripple <5ns

MECHANICAL

Dimensions φ322*261mm

Connector TNC female

Weight ≤5.6kg

Mounting BSW5/8"-11 screw, depth≥22mm

ENVIRONMENTAL

Temperature

Operating -40°C to +85°C

Storage -55°C to +85°C

Humidity 95% non-condensing

Water/Dust Resistance IP67

Regulatory Compliance NGS,CE, FCC, RoHS

For the most recent details of this product:
<https://en.harxon.com/products-detail.php?Proid=100>

en.harxon.com

sales@harxon.com

9/F, Block B, Building D3, TCL International
 E City, NO.1001 Zhongshanyuan Road,
 Nanshan District, Shenzhen, China

Tel: +86-755-26989948

Fax: +86-755-26989994

Version 1 Specifications subject to change without notice.
 ©2020 Harxon Corporation. All rights reserved.
 Printed in China
 October 2020

Structure & Phase Center Drawing (mm)

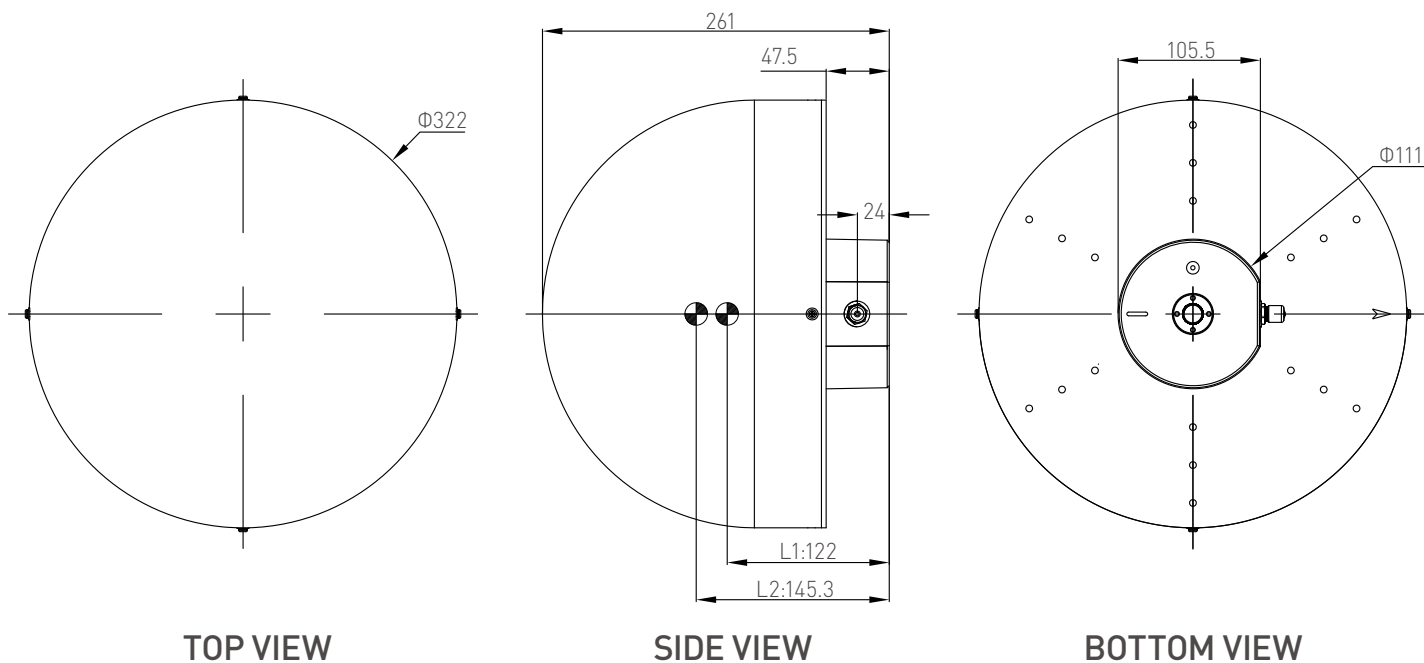

Undeclared Tolerance: ±0.3mm

