

OEM GNSS Antenna HX-CU7001A

HX-CU7001A Embedded GNSS Antenna for UAVs Applications

The embedded HX-CU7001A GNSS antenna is a high gain, low profile UAV antenna that provides reliable and consistent positioning services for high dynamic applications such as UAVs and precision agriculture. Its small form factor, delicate design, high sensitivity and low power consumption makes it ideal to be integrated into UAVs that are applied to surveillance, infrastructure inspection, public security, remote sensing, and precision agriculture.

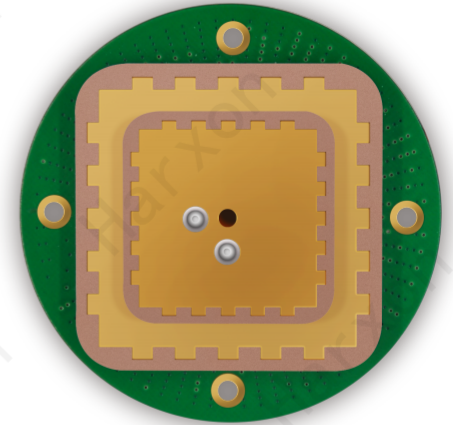

RELIABLE AND CONSISTENT SIGNAL TRACKING

The Harxon HX-CU7001A is capable of receiving signals from GPS, GLONASS, Galileo, and BeiDou, QZSS and SBAS. It offers a very stable phase center variation with advanced multipoint feeding technology, exceptional low elevation satellite tracking with symmetric radiation patterns, high gain with ultralow signal loss, as well as outstanding wide-angle circular polarization (WACP) ensures excellent positioning accuracy.

SMALL SIZE, LIGHT WEIGHT, AND LOW POWER CONSUMPTION

The HX-CU7001A antenna is ideal for UAV applications due to its compact and light weight design, with dimensions $\Phi 60 \times 16.7$ mm and weight 60g. The embedded design of the antenna decreases the whole weight of the UAV for an overall reliability against waterproof, shock and assembly. Customization of cables and connectors of HX-CU7001A is available.

STRONG ANTI-INTERFERENCE PERFORMANCE

The HX-CU7001A antenna equips a robust pre-filtered LNA to minimize de-sensing from high level out-of-band signals, and restraints possible electromagnetic interferences for consistent and reliable GNSS signals. It excels in applications in congested environments such as agriculture, forest, UAV patrolling and GIS that face unwanted signal interference and blockage.

KEY FEATURES

- Comprehensive GNSS support: GPS, GLONASS, Galileo, BeiDou and QZSS
- Centimeter phase center repeatability
- Improved signal filtering and excellent multipath rejection
- Embedded design for improved UAVs reliability
- Low profile design, light weight

OEM GNSS Antenna HX-CU7001A

PERFORMANCE

Signal Received	
GPS	L1/L2
GLONASS	L1/L2
GALILEO	E1
BDS	B1/B2/B3
QZSS	L1/L2
SBAS	L1
Nominal Impedance 50Ω	
Polarization RHCP	
Axial Ratio ≤3dB	
Azimuth Coverage 360°(omni-directional)	
Output VSWR ≤2.0	
Peak Gain 2.5dBi	

LOW NOISE AMPLIFIER

LNA Gain	36±2dB
Noise Figure	≤2dB
Output VSWR	≤2.0
Passband Ripple	±2dB
Operation Voltage	+3.3 to +12VDC
Operation Current	≤45mA
Differential Propagation Delay	≤5ns

MECHANICAL

Dimensions	Φ60x16.7mm
Connector	MMCX
Weight	≤60g
Mounting	4x M2.5 Screws

ENVIRONMENTAL

Temperature	
Operating	-40°C to +85°C
Storage	-55°C to +85°C
Humidity	95% No-condensing

en.harxon.com

sales@harxon.com

9/F, Block B, Building D3, TCL International
E City, NO.1001 Zhongshanyuan Road,
Nanshan District, Shenzhen, China

Tel: +86-755-26989948

Fax: +86-755-26989994

Version 1 Specifications subject to change without notice.
©2020 Harxon Corporation. All rights reserved.
Printed in China
June 2020

Structure & Phase Center Drawing (mm)

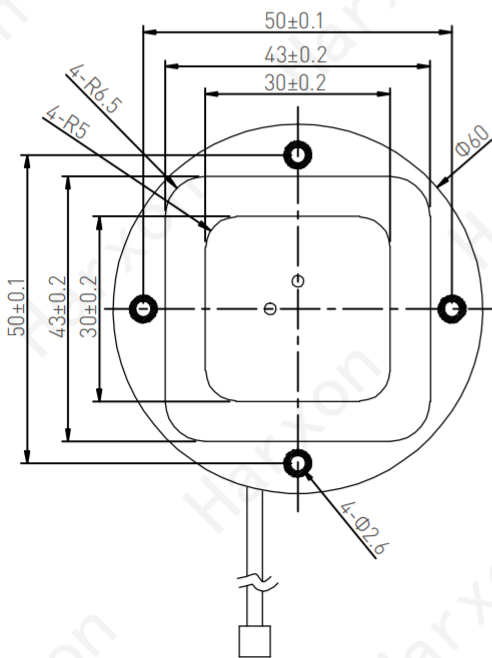

TOP VIEW

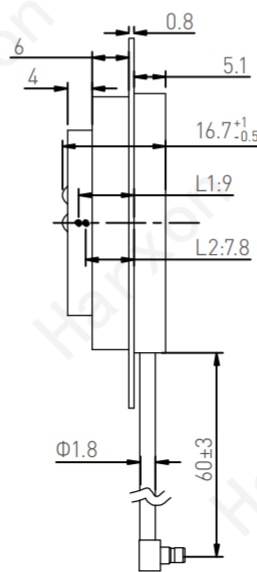

SIDE VIEW

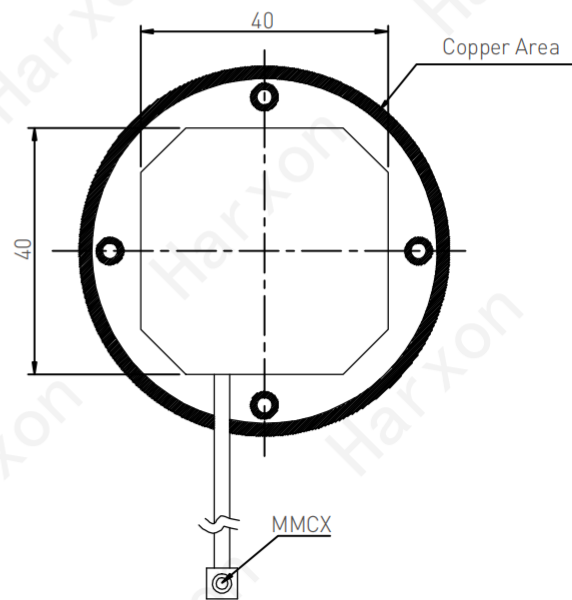

BOTTOM VIEW

Undeclared Tolerance: ±0.3mm