

Helix Antenna HX-CUX012A

Harxon HX-CUX012A embedded helix antenna is designed for high precision positioning of UAV and offers superior satellite signal tracking, including GPS, GLONASS, GALILEO, Beidou, QZSS, SBAS, IRNSS as well as L-Band correction service. It provides excellent axial ratios, enables excellent multipath mitigation and a very precise phase center. As the helix antenna with the lowest profile ever, it is easy to be integrated, ideal for various UAV applications such as aerial photography, remote sensing, infrastructure inspection, traffic control and public security.



LOW PROFILE, EASY TO BE INTEGRATED

HX-CUX012A is designed with extremely low profile (21.9mm) and weighs only 10g with a compact dimension of $\Phi 46 \times 21.9\text{mm}$, making it ideal to be integrated into UAVs, surveying and monitoring devices. It reduces the overall weight of applications and meets the strict demands of low profile.

HIGH PHASE CENTER STABILITY AND CONSISTENT PERFORMANCE

The HX-CUX012A antenna features a multi-point feeding technology that ensures a high phase center stability with centimeter level accuracy. It has a high peak gain of 3.0 dBi and excellent axial ratios, enabling excellent multipath mitigation and a very precise phase center.

STRONG ANTI-INTERFERENCE PERFORMANCE

HX-CUX012A optimizes circuit layout and equips a robust pre-filtered LNA that features an excellent out-of-band interference rejection performance and restrains possible unwanted electromagnetic interference, providing reliable GNSS signals for easy integration into positioning solutions.

ADVANCED PATENTED D-QHA TECHNOLOGY

The HX-CUX012A antenna adopts patented D-QHA technology for stable performance of wide-angle circular polarization (WACP), which ensures exceptional low elevation satellite tracking while maintaining high gain and providing reliable signal tracking. This consistent performance makes it ideal option for UAVs even under challenging environments.

KEY FEATURES

- Comprehensive GNSS support: GPS, GLONASS, Galileo, Beidou, QZSS, SBAS as well as L-Band correction service
- Excellent RHCP signal reception and signal-to-noise ratio
- Centimeter phase center repeatability, high gain at low elevation
- Improved signal filtering and excellent multipath rejection
- Extremely low profile (21.9mm) and light (10g)

Helix Antenna HX-CUX012A

PERFORMANCE

Signal Received	
GPS	L1/L2/L5
BDS	B1/B2/B3
GLONASS	L1/L2/L3
GALILEO	E1/ E5a/E5b/E6
QZSS	L1/L2/L5/L6
SBAS	L1/L5
IRNSS	L5
L-Band	
VSWR	≤2
Polarization	RHCP
Gain RHCP (maximum)	
1166~1278 2.8dBi	
1559~1612 3.3dBi	
L-Band 1.5dBi	
Nominal Impedance	50Ω
Beam Width	110°(typical)

Axial Ratio	≤3dB
LNA Gain	33±2dB
Noise Figure	≤2dB
Phase Centre Variation	±3mm
Operation Voltage	+3.3~+12VDC
Operation Current	≤40mA
Group Delay Ripple	≤15ns

MECHANICAL

Dimensions	φ46*21.9mm
Weight	8g
Connector	IPEX I
Mounting	3 M1.6 screws fixed

ENVIRONMENTAL

Operating Temperature	-40℃~+70℃
Storage Temperature	-55℃~+70℃
Humidity	95% non-condensing
Regulatory Compliance	FCC, CE, RoHS, REACH

en.harxon.com

sales@harxon.com

9/F, Block B, Building D3, TCL International

E City, NO.1001 Zhongshanyuan Road,

Nanshan District, Shenzhen, China

Tel: +86-755-26989948

Fax: +86-755-26989994

Version 1 Specifications subject to change without notice.

©2023 Harxon Corporation. All rights reserved.

Printed in China

March 2023

Structure& Phase Center Drawing (mm)

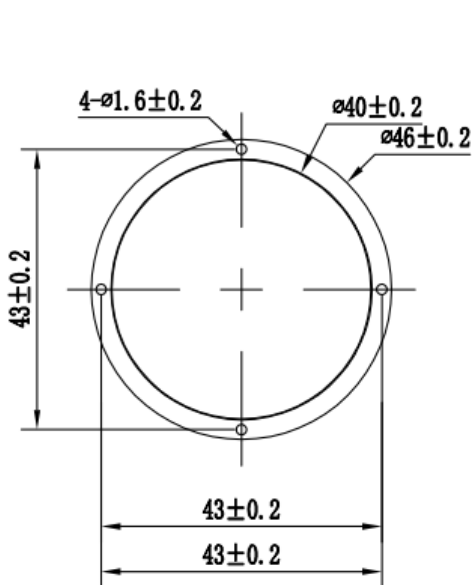

TOP VIEW

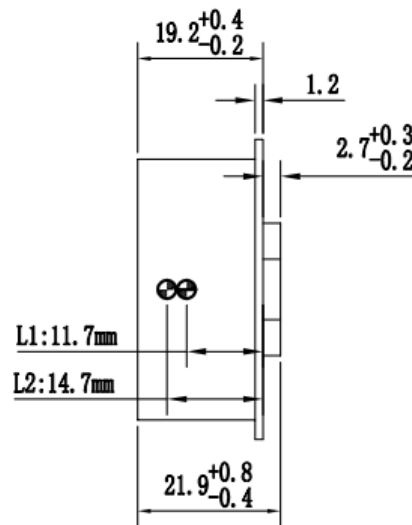

SIDE VIEW

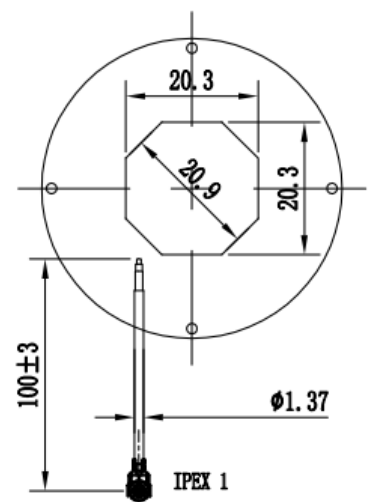

BOTTOM VIEW

Undeclared tolerance:±0.3mm