

# Ruggedized GNSS Antenna HX-CVX606A

**Harxon**  
a *BDStar* company

## RELIABLE AND RUGGEDIZED WITH MILLIMETER ACCURACY

Harxon HX-CVX606A GNSS antenna is built into ruggedized enclosure with metal base, which allows the antenna to be used in high shock and vibration conditions. HX-CVX606A can provide millimeter level accuracy with strong anti-interference performance and stable phase center, ideal for surveying in tough environments and I-construction applications including autonomous vehicles and automatic operation.

### RUGGEDIZED ENCLOSURE FOR TOUGH ENVIRONMENTS

HX-CVX606A is built into an independent aerodynamic enclosure with ruggedized metal base. The IP69K rating housing protects the product from dust, rain and sunlight, also enables withstanding of high shock and vibration. Its standard TNC-K connector with anti-collision cap design ensures optimal reliability in challenging environments.

### CONSISTENT PERFORMANCE ACROSS FULL FREQUENCY BANDS

HX-CVX606A offers full support for reliable and consistent satellite signals tracking, including GPS, GLONASS, Galileo, BeiDou, QZSS, IRNSS, SBAS as well as L-Band correction services. Also, it exhibits a very stable phase center variation with advanced multipoint feeding technology, exceptional low elevation satellite tracking with symmetric radiation patterns, high gain with ultralow signal loss, as well as outstanding wide-angle circular polarization (WACP), which ensures excellent positioning accuracy.

### TRACKING IN COMPLEX ENVIRONMENTS

The high gain and wide beam width features ensure exceptional low elevation signal tracking performance, which make sure the antenna receives reliable and consistent signals even under harsh environment where blockage exists.

### STRONG ANTI-INTERFERENCE PERFORMANCE

The advanced LNA (Low Noise Amplifier) of the antenna excels in improved signal filtering and out-of-band rejection by restraining unwanted electromagnetic interferences, providing strong anti-interference performance for consistent and reliable GNSS signals and avoiding the risk of loss tracking even under complicated environments such as overcrowded urban areas or communication base stations where profound electromagnetic interference exists.



### KEY FEATURES

- Comprehensive GNSS support: GPS, GLONASS, Galileo, BeiDou, QZSS, IRNSS, SBAS as well as L-Band correction services
- Millimeter PCV repeatability( $\leq 2\text{mm}$ )
- Improved signal filtering and excellent multipath rejection
- IP69K ruggedized enclosure for tough environments
- Solid metal base, high shock & vibration resistance



# Ruggedized GNSS Antenna HX-CVX606A

**Harxon**  
a *BDStar* company

## PERFORMANCE

### Signal Received

Upper Band	1.525 to 1.615 GHz
Lower Band	1.165 to 1.3GHz
GPS	L1/L2/L5
GLONASS	L1/L2/L3
GALILEO	E1/E5a/E5b/E6
BDS	B1/B2/B3
QZSS	L1/L2/L5/L6
IRNSS	L5
SBAS	L1/L5
L-Band	

**Nominal Impedance** 50 $\Omega$

**Polarization** RHCP

**Axial Ratio**  $\leq 3$ dB

**Azimuth Coverage** 360°

**Output VSWR**  $\leq 2.0$

**Peak Gain** 5.5dBi

## LOW NOISE AMPLIFIER

**LNA Gain** 40 $\pm$ 2dB

**Noise Figure**  $\leq 2$ dB

**Output VSWR**  $\leq 2.0$

**Passband Ripple**  $\pm 2$ dB

**Operation Voltage** +3.3 to +18VDC

**Operation Current**  $\leq 45$ mA

**Differential Propagation Delay**  $\leq 5$ ns

## MECHANICAL

**Dimensions**  $\phi 150 \times 57.3$ mm

**Connector** TNC-K

**Weight**  $\leq 800$ g

### Mounting

Pole Mount

Coarse threaded 5/8"-11, thread hole depth

14-18mm

Screws Mount M8 screws

## ENVIRONMENTAL

### Temperature

Operating -45°C to +85°C

Storage -55°C to +85°C

**Humidity** 95% no-condensing

**Ingress Protection Rating** IP67, IP69K

**Salt Spray** 96h

**Vibration** 9.8gRMS, 24-2000Hz

**Shock** 3 vertical axis 75Gs, 6ms

### EMC (RF Input Static)

Connected: 8KV, Air: 15KV, 10 times

**Regulatory Compliance** CE FCC ROHS

### en.harxon.com

sales@harxon.com

9/F, Block B, Building D3, TCL International

E City, NO.1001 Zhongshanyuan Road,

Nanshan District, Shenzhen, China

Tel: +86-755-26989948

Fax: +86-755-26989994

**Version 1** Specifications subject to change without notice.

©2022 Harxon Corporation. All rights reserved.

Printed in China

June 2022

# Ruggedized GNSS Antenna HX-CVX606A

**Harxon**  
a *BDStar* company

## Structure & Phase Center Drawing (mm)

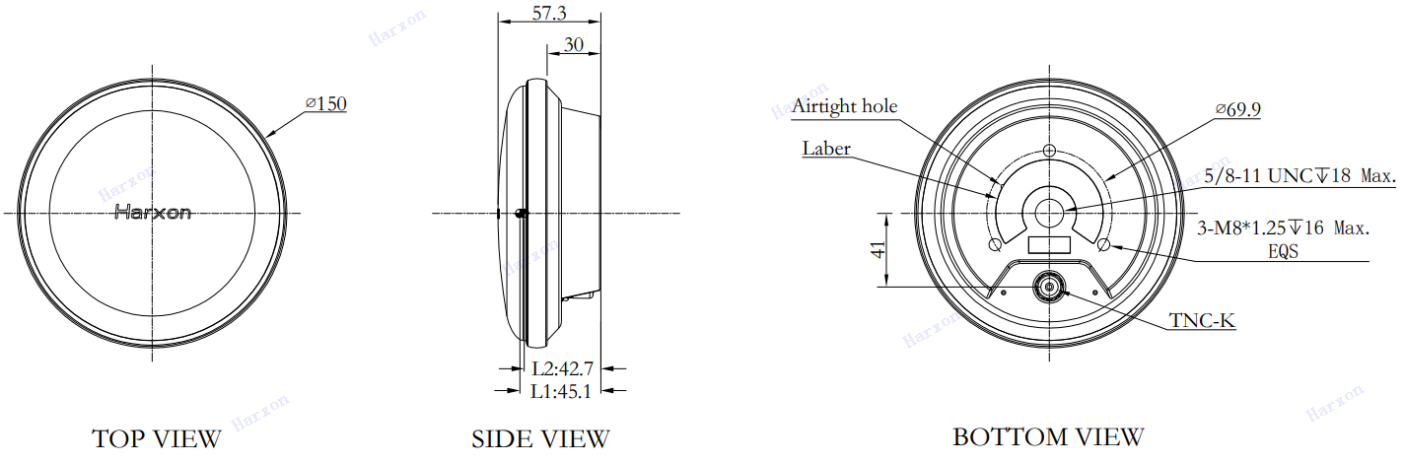

TOP VIEW

SIDE VIEW

BOTTOM VIEW

(Customizable enclosure)

Undeclared Tolerance:  $\pm 0.3 \text{ mm}$



Downward TNC-K Connector

## Product Label

The content of the label is shown as below. The S/N code needs to be written according to the program file and the actual situation. The following figures are only for illustration.

Label 1: Circular label, size  $\varnothing 59.7 \times T0.4 \text{ mm}$ .

Label 2: size  $23 \times 9 \text{ mm}$

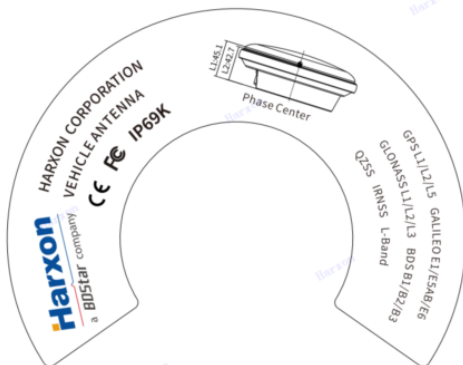

Model: HX-CVX606A

S/N: C21049000162

